

Audio and Power subsystem for advanced applications processors

The DA9025 is a very flexible circuit designed for low power systems which typically include both digital and analog functions. It is ideally suited to systems using advanced microcontrollers or DSPs which require separate core and peripheral supplies

The DA9025 provides a basic system level power management solution, handling ON/OFF control, power sequencing and battery monitoring and can act as a core of a system. Additional functionality such as extra regulators or battery charging can be added using readily available standard components allowing the designer to quickly configure a complete system.

Integrated are four low dropout voltage regulators, using Dialog Semiconductor's patented Smart Mirror™ technology. Smart Mirror™ simplifies system design and delivers low power operation, whilst at the same time maintaining high dynamic performance. To allow optimum power consumption the DA9025 also includes a DCDC buck converter featuring integrated switching FETS to minimize external components.

Designed to offer great flexibility the DA9025 can operate with or without a host controller.

In addition to providing the regulated supplies the device monitors the power source for under and over voltage conditions and has internal thermal monitoring to protect against overstress

The DA9025 is packaged in a small 24 lead 4x4mm QFN package, which coupled together with a low external component count, enables a complex power management solution to be realized in just 1cm² of PCB area



Features

- Integrates core power management functions in portable equipment
- Standalone or μ P controlled
- Small size 4x4QFN

Functions

- 4 high performance low dropout regulators
- RTC supply
- High efficiency DC-DC buck converter
- Supply monitoring

Applications

- Cellular telephones
- Digital still cameras
- PDA
- Portable instruments

Overview

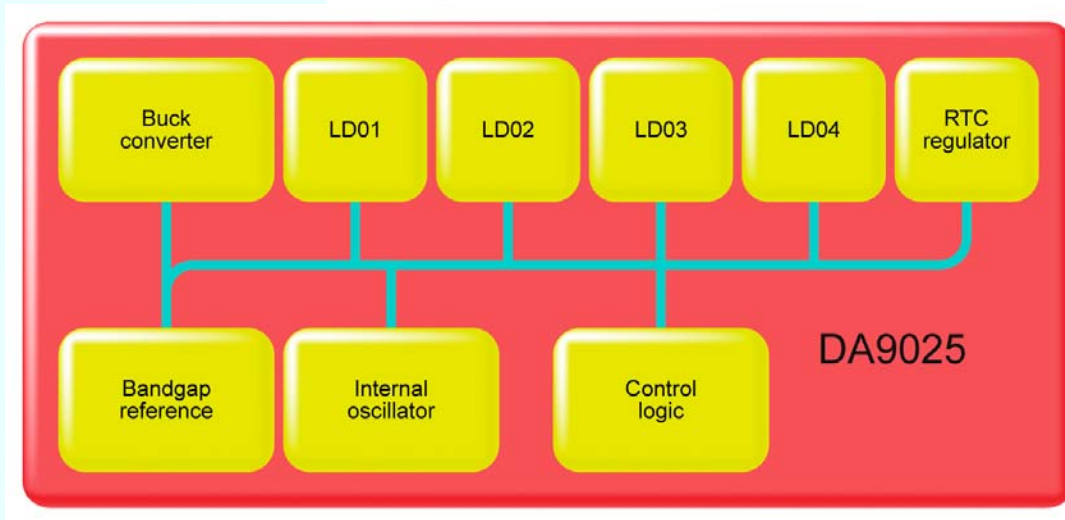

Voltage Regulator section highlights

- High power supply rejection, typically 80dB @ 1KHz
- Dynamic biasing for high efficiency
- Quiescent current typically 15µA/regulator @ 10mA
- Programmable output voltage
- Small external 2.2 µF decoupling capacitors for low cost and PCB area
- Over current and thermal protected outputs
- High efficiency buck converter 0.85V-3.3V output
- Asynchronous mode for high efficiency at low load

System Control Highlights

- 2 device enables ONKEY (active low) and EXTON(Active high)
- Supports standalone operation
- I2C control for additional functionality
- Watchdog function
- Overvoltage, undervoltage protection
- Hardware reset via ONKEY input
- Autonomous operation for precharge function

Package

- 24 QFN 4*4*0.8mm, 0.5mm pitch

Version 1.0 August 20th 2008

Dialog Semiconductor worldwide offices

Germany (Headquarters)

Tel: (+49) 7021 805-0

Fax: (+49) 7021 805-100

Japan

Tel: (+81) 3 3215 5123

Fax: (+81) 3 3215 5124

Korea

Tel: (+82) 2 6007 2303

Fax: (+82) 2 6007 2001

Taiwan

Tel: (+886) 37 598 166

Fax: (+886) 37 595 026

USA

Tel: (+1) 888 809 3816

Fax: (+1) 408 328 9275

United Kingdom

Tel: (+44) 1793 757700

Fax: (+44) 1793 757800

Email: enquiry@diasemi.com

Web: www.dialog-semiconductor.com